



AEROSCALES *powered by CH-Aero*

Weighing Equipment AW5-2L

Enclosed you find information about our company Aeroscales and our AW5-2L robust weighing equipment.

If you would like to receive a customised quotation, we kindly invite you to reach out to us. You can send your inquiry to:

sales@aeroscales.com or michelle@ch-aero.com

We are here to assist you and feel free to contact us for any additional information or assistance you may require

Kind regards ,

Michelle Arentz
Sales Director
Aeroscales *powered by CH-Aero*



Introducing CH-Aero and Aeroscales



Mr Coen Smit, the founder and managing director of CH-Aero and Aeroscales has had a distinguished career in the aviation industry, spanning over 30 years. Throughout his journey, he has held various roles in both airlines and maintenance companies, giving him a comprehensive understanding of the challenges faced by aviation companies.

Aviation industry

Mr Smits extensive experience in the industry has equipped him with invaluable insights into the inner workings of airlines and maintenance companies. He

knows firsthand the obstacles they encounter and the complexities they navigate on a daily basis. This deep understanding allows us to develop products and solutions from a user's perspective.

AW5-2 weighing equipment

At Aeroscales, we believe in crafting smart, hassle-free and easy to use weighing equipment, that address the real needs of our customers. Aeroscales ability to bridge the gap between industry requirements and user expectations has resulted in the AW5-2 series scales.

Easy to use

Our weighing scales are designed to be easily used. The platforms are extremely robust, reliable, accurate and, above all, incredibly user-friendly. By choosing the scales of Aeroscales you simplify your operations, saving you time and resources.

Specifications AW5-2L weighing equipment

What is needed?

AW5-2L scale:



- Capacity: 30t kgs, 66.000lbs
- Platform dimensions: 700x450 x60 mm. 27,5x17,7x2,4"
- weight of the scale: approx. 50kg, 110lb.



Properties weighing platform:

- Special construction of aluminium
- Low profile platform, frame of solid welded steel construction
- Equipped with 12 RVS load cells, model RSB3 1000 OHM
- Equipped with smart transport positioning wheels
- Equipped with 2 handles on each side for easy handling

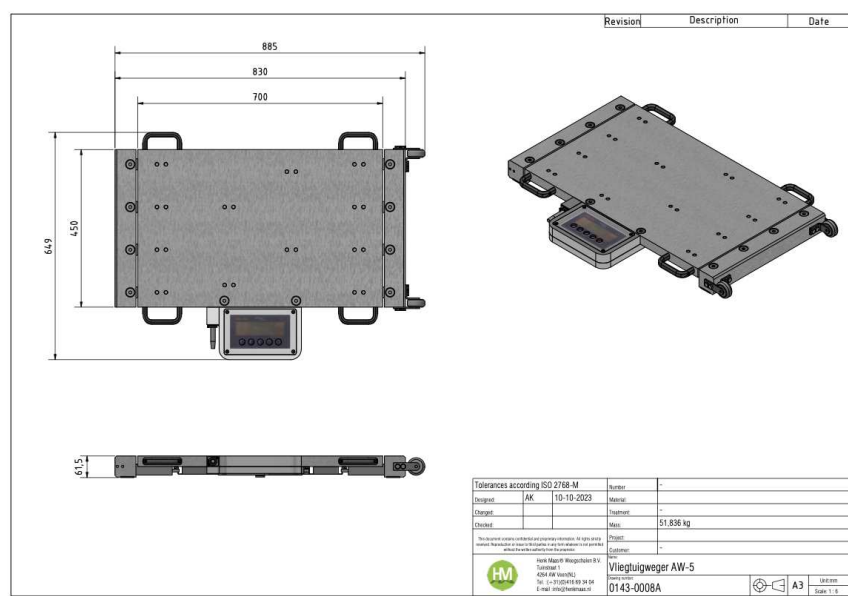

properties weighing indicator

- Mounted weighing indicator with LCD display for reading the weight of each weighing platform, in kg or lb. (1kg/2,2lbs division!)
- Simple, water-protected keyboard with different function keys: Taring (manual, automatic or pre-set), printing, on/off, a freely programmable function key and switching between kgs and lbs.
- Functions: tare, automatic tare, high resolution weighing (10x more accurate), net / gross indication, cumulative weighing, in / out weighing, hold and peak function.
- Clearly readable, backlit LCD display, height 25 mm./0,98"
- ABS plastic housing, protection class IP54. Extra protection provided by aluminium construction.
- Power supply: internal, rechargeable battery (approx. 40 hours operating time if fully charged), incl. mains adapter / charger.
- Equipped with 2x RS-232 / C port.

Ramps and bridges

- Robust
- Light weight
- Material HMPE 500R
- Handles on the side for easy handling

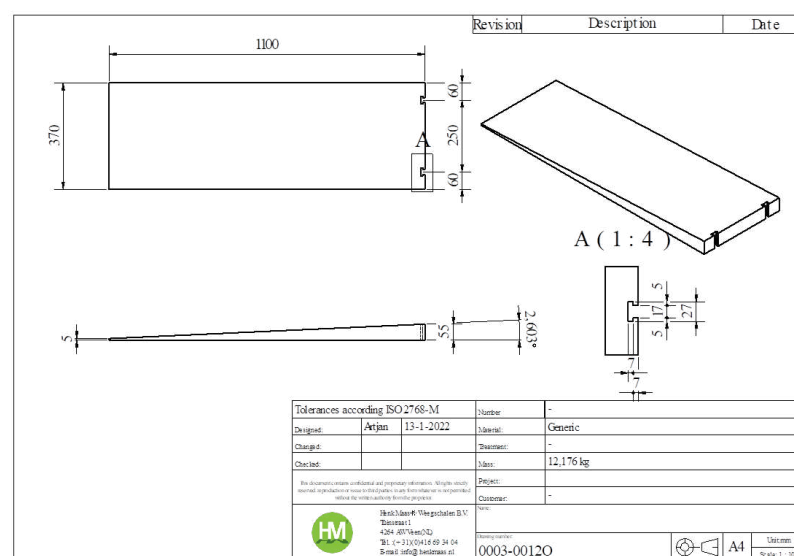

Optional-Wireless



The AW5-2 scales can also be purchased with additional wireless weighing option. The WiFi is fully integrated in the scales. The wireless package comes with

- Laptop
- Router
- Software
- wifi per scale

Optional - Cart

A transport cart can be modified accordingly to the customers need. The cart has the following characteristics:

- Made from robust painted steel
- 2 fixed wheels and 2 swivelling wheels
- 4 tyres
- handles on the side for easy handling



Optional-lifetime warranty

Our lifetime warranty is initially contracted for a period of 5 years and will automatically renew on an annual basis thereafter. Included in the lifetime warranty is:

- Yearly Calibration at our facility
- In the event of any malfunction or issue we provide a complimentary replacement of a loan scale during the process

Excluded:

- Transportation costs
- In the event that the malfunction or issue is a result of improper use we are not able to provide a free replacement

What our customers have to say about us...



Customer Testimonials

"LST is highly satisfied with CH-Aero's service.



especially their swift response time and crucial flexibility for our maintenance operations. Their well-maintained equipment is always ready for use, ensuring seamless operations."

"CH-Aero perfectly fit our expectations.



Their reliability, discipline and professionalism makes us committed to serving a client. "

Customer Testimonials



"Contacting CH Aero in 2018 for weighing an ATR led to the use of weighing plates. This innovation improved weighing

processes for the B737 and A320 series, prompting the purchase of a set that was later expanded for weighing the A330. Using one set for all aircraft streamlined operations, making weighing faster and more efficient."

"CH-Aero is very reliable, flexible and professional company and equipped with perfect equipment. We are glad to have CH-Aero as service supplier."

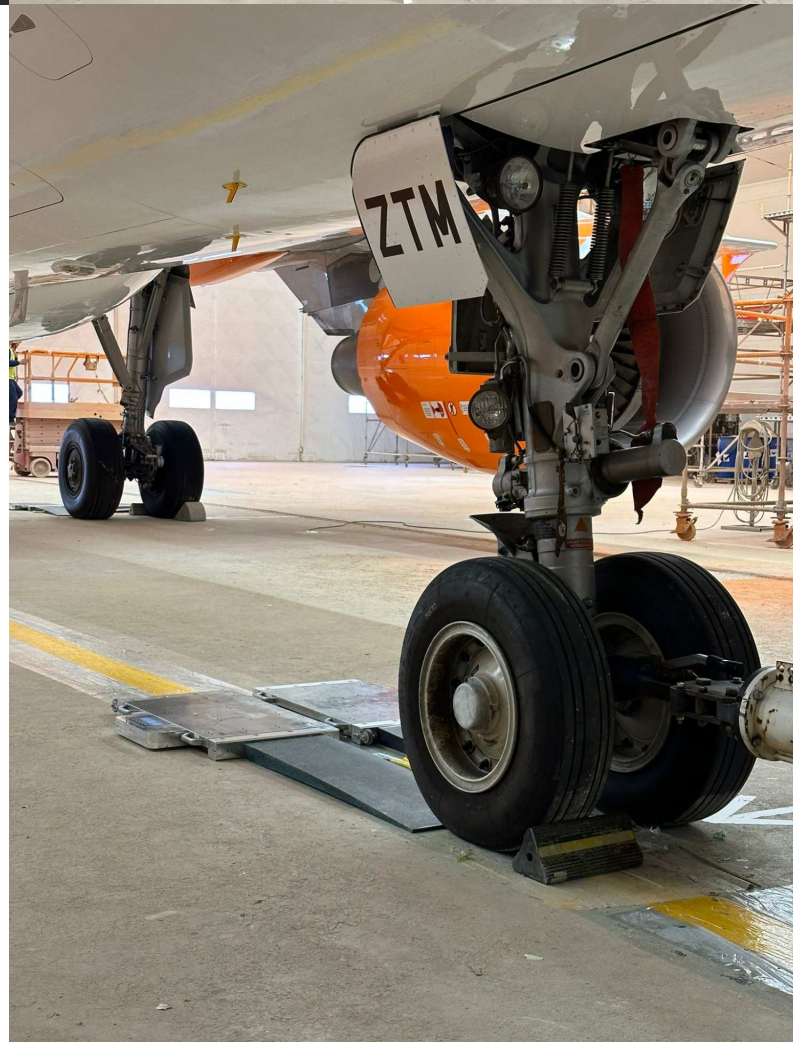

CONTACT DETAILS

Aeroscales

Amsteldijk Noord 68
1422 XX Uithoorn
The Netherlands
www.aeroscales.com
sales@aeroscales.com
michelle@ch-aero.com





"Precision in every pound, flexibility in every task, customer-centricity at our core and reliability in every measure"

-CH-Aero and Aeroscales-